

MINI**PRO**™ GEAR DRIVEN SPRINKLER SETTING INSTRUCTIONS

NOTE: The **MiniPro** is factory preset with a 40° arc setting, and includes a pre-installed #1.5 nozzle.

CHANGING A NOZZLE

1► REMOVING THE NOZZLE RETENTION SCREW

Use your K-Key or a small flat blade screwdriver to remove the nozzle retention screw by turning counter-clockwise to remove and clockwise to re-install.

2► PULL UP THE RISER

Insert the K-Key in the keyhole on the top of the nozzle turret and turn the key 1/4 turn to insure that the key does not slip out of the keyhole when you pull it up. Firmly pull up the entire spring-loaded riser to access the nozzle socket. Hold the riser assembly up with one hand.

3► REMOVING THE NOZZLE

Insert the end of the K-Key, hook side up, into the tall slot along the right side of the nozzle and pull up to pop out nozzle. **NOTE:** Do not put the K-Key or any instrument into the nozzle opening.

4► INSTALLING A NOZZLE

Press the desired nozzle into the nozzle socket. Make sure the nozzle number is visible and the nozzle “Wing” is up. Then, re-install the nozzle retention screw. **NOTE:** The nozzle retention screw is also a break-up screw and used to adjust the distance of the spray.

SETTING THE ARC ADJUSTMENT

1► FINDING THE LEFT START POSITION

Place your finger on the top center of the nozzle turret. Rotate the turret to the right until it stops and then back to the left until it stops. Notice the position of the nozzle arrow. This is the “Left Start” position. The sprinkler will begin spraying from this position and rotate clockwise until it reaches the right “Arc Stop”.

2► ORIENTING THE LEFT START POSITION

Insert the K-Key in the keyhole on the top of the nozzle turret and turn the key 1/4 turn to insure that the key does not slip out of the keyhole when you pull it up. Being careful not to allow the nozzle turret to turn, firmly pull up the entire spring-loaded riser. Hold the lower riser assembly up with one hand. Now turn only the lower riser clockwise or counter-clockwise until the nozzle arrow is pointing where you want the sprinkler to begin spraying.

3► CHANGING THE ARC

Insert the K-Key or a small flat blade screwdriver into the Arc Set Adjustment slot. Turn clockwise to increase the arc or counter-clockwise to decrease the arc.

NOTE: The arc set arrow in the center of the nozzle turret rotates to show the current setting.

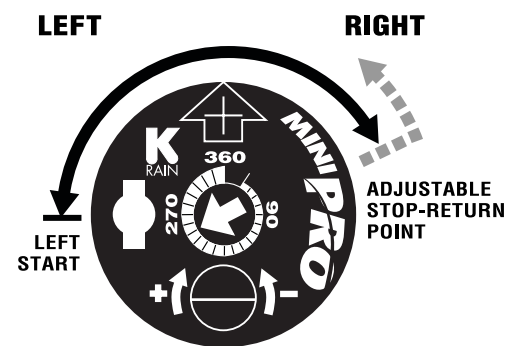
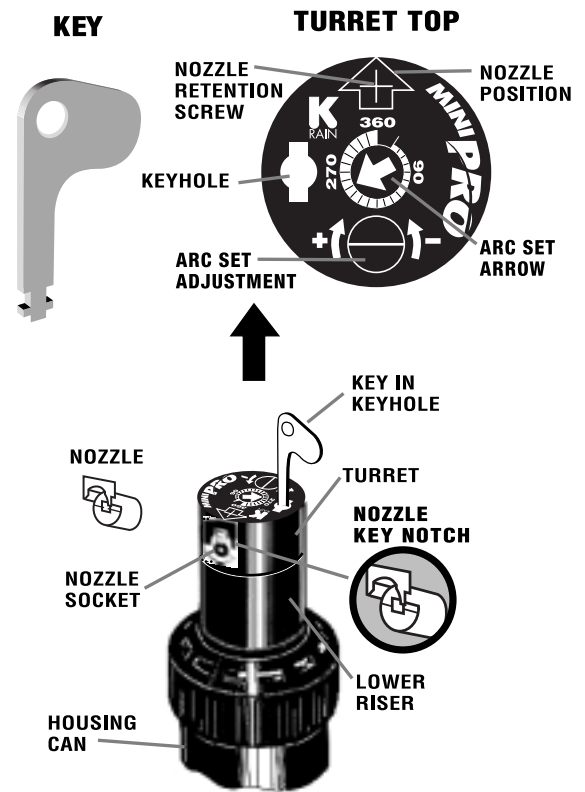

**ARC SELECTION:
30° TO 360°**

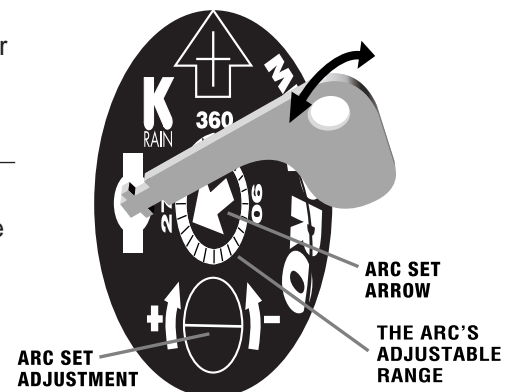

MINIPRO™ GEAR DRIVEN SPRINKLER SETTING INSTRUCTIONS

SPRINKLER INSTALLATION

1► INSTALL AND BURY

Thread the sprinkler on the pipe. Bury the sprinkler flush to grade.

NOTE: Do not use pipe dope. Gear driven sprinklers and pop-up sprays should not be installed on the same watering zone.

2► INSPECTING THE FILTER

Unscrew the top and lift the complete sprinkler assembly out of the housing can. The filter is located on the bottom of the sprinkler assembly and can easily be pulled out, cleaned and re-installed.

3► WINTERIZATION TIPS

When using an air compressor to remove water from the system please note the following:

- 1) Do not exceed 30 PSI.
- 2) Always introduce air into the system gradually to avoid air pressure surges. Sudden release of compressed air into the sprinkler can cause damage.
- 3) Each zone should run no longer than 1 minute on air. Sprinklers turn 10 to 12 times faster on air than on water. Over spinning rotors on air can cause damage to the internal components.

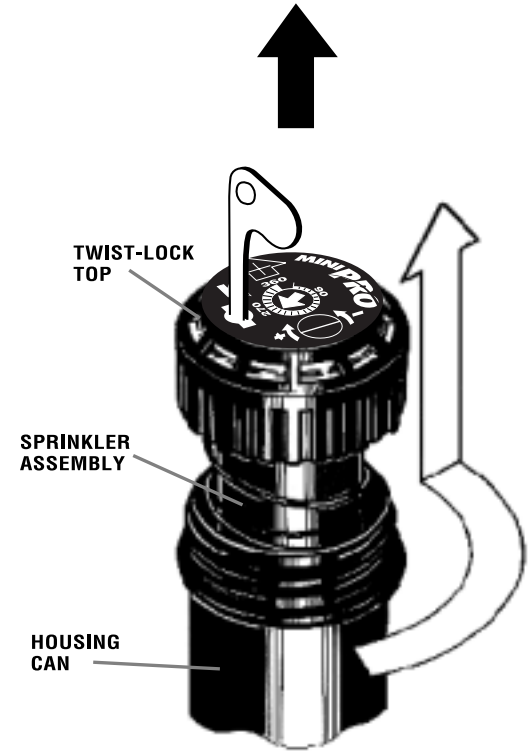

STANDARD NOZZLE PERFORMANCE

Nozzle	U.S.			METRIC				
	Pressure PSI	Radius Ft.	Flow GPM	Pressure KPa	Pressure Bars	Radius Meters	Flow L/M	Flow M ³ /H
#1.5 Factory Installed Nozzle	30	23'	1.4	207	2.0	7.0	5.3	.4
	40	24'	1.7	276	3.0	7.3	6.4	.4
	50	24'	1.9	345	3.5	7.3	7.2	.5
#0.75	30	17'	.75	207	2.0	5.2	2.8	.2
	40	17'	.8	276	3.0	5.2	3.0	.2
	50	18'	.9	345	3.5	5.5	3.4	.2
#1	30	20'	0.9	207	2.0	6.1	3.4	.2
	40	21'	1.2	276	3.0	6.4	4.5	.3
	50	21'	1.3	345	3.5	6.4	4.9	.3
#2	30	25'	1.8	207	2.0	7.6	6.8	.5
	40	27'	2.1	276	3.0	8.2	8.0	.5
	50	27'	2.4	345	3.5	8.2	9.1	.6
#3	30	28'	2.7	207	2.0	8.5	10.2	.7
	40	30'	3.0	276	3.0	9.1	11.4	.8
	50	30'	3.3	344	3.5	9.1	12.5	.8

Data represents test results in zero wind for MiniPro. Adjust for local conditions. Radius may be reduced with nozzle retention screw.

